



Mobilfer



BANCHI
COUNTERS

Banconate componibili Modular counters

IT

Semplicità, robustezza e facile componibilità, sono alcune tra le prerogative per le quali le banconate Mobilfer vengono notoriamente apprezzate e scelte fra le molteplici proposte esistenti nel medesimo settore.

La linea elegante, frutto di un design accurato, permette loro di **inserirsi negli ambienti più svariati**, accostandosi sempre con personalità, a qualsiasi tipo di arredamento. I modelli proposti sono stati studiati al fine di **risolvere le diverse problematiche che si presentano in numerosi settori merceologici**. Il lato interno delle banconate, infatti, può essere strutturato in differenti configurazioni a seconda delle esigenze operative dell'utilizzatore. Portine con piani e ribaltine, cantonali a 90° a 45° e quadrangolari, costituiscono gli utili **accessori di completamento**.

La struttura metallica, dimensionata in modo da garantire una grande robustezza, è realizzata in lamiera di acciaio di alta qualità, pretrattata mediante opportuno procedimento anticorrosivo, e successivamente verniciata a polveri epossidiche polimerizzate a 190° C. Questo procedimento, permette alle banconate Mobilfer una **lunga durata nel tempo**, oltre ad ottenere un notevole effetto cromatico. La vasta gamma di pannelli frontali, disponibili sia in laminato plastico che in lamiera verniciata di vari colori, permette una **scelta personalizzata**, conforme al gusto ed alle esigenze di arredi particolari.

Tutti i piani superiori hanno i bordi laterali protetti da fianchi in ABS antiurto. Il lato anteriore presenta una massiccia stonatura nella quale è inserito un gradevole profilo sempre in ABS. È prevista inoltre la **possibilità di realizzare forature** (sia sul piano superiore che sulla struttura) complete di tappi in plastica.

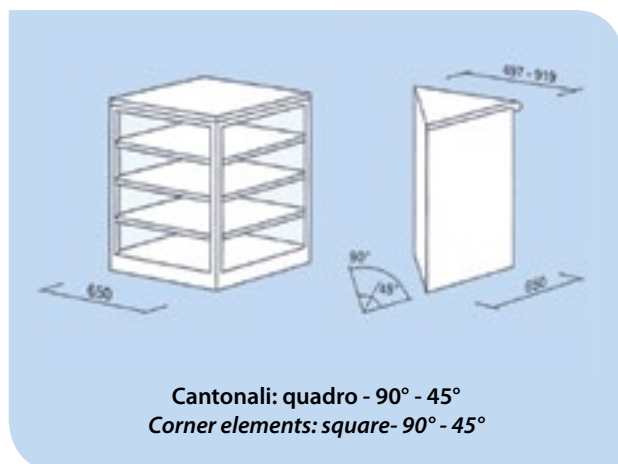

GB

*Among the many existing proposals in the sale counters sector, Mobilfer products are usually appreciated and chosen for their **simplicity, robustness and easy to combine elements**.*

*Moreover, thanks to their elegant lines which are the result of careful choices of design, they **can fit into many different environments**, complementing any surrounding furniture. The different models offered have been studied in order to solve all the operational need of the sales, in any sectors. For this purpose, **the interiors can be constructed on the basis of specific needs**, by choosing from the numerous possibilities available.*

*Doors with folding shelves and flaps, corner elements at 90 and 45 degrees and square corner elements, constitute useful **complementary accessories**.*

*The metal structure, designed to ensure great strength, is made of high quality sheet steel, pre-treated with appropriate anti-corrosion process and then painted with epoxy powder polymerized at 190 °C. This procedure allows to Mobilfer counters from one side to **last a long time** and on the other side to obtain a remarkable chromatic effect.*

Benches can be coated with a wide range of front panels, available in both plastic laminate that painted sheet metal of various colors, customizable according to the needs and tastes of each client.

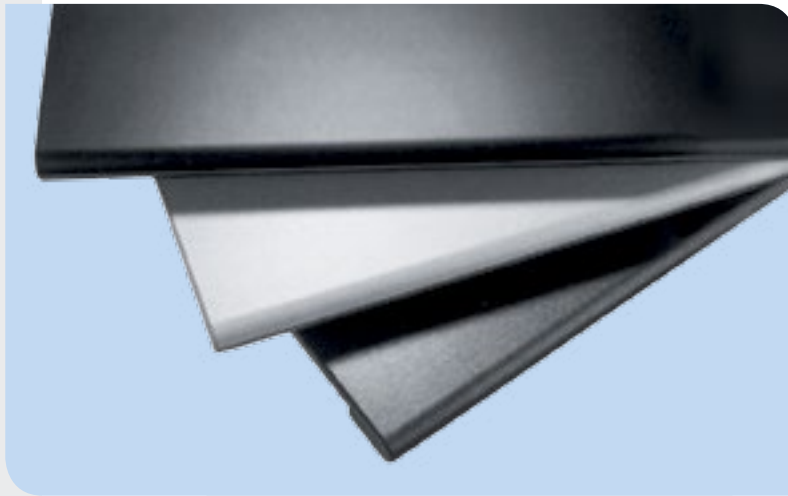

IT

Tutti i piani superiori hanno i bordi laterali protetti da fianchi in ABS antiurto. Il lato anteriore presenta una massiccia stonatura nella quale è inserito un gradevole profilo sempre in ABS. E' prevista inoltre la possibilità di realizzare forature (sia sul piano superiore che sulla struttura) complete di tappi in plastica.

Il piano superiore può essere in **laminato colore grigio chiaro** (profondità 730 mm) oppure in **laminato antracite** (profondità 760 mm) oppure in **linoleum nero** (profondità 730 mm).

I laminati sono realizzati in truciolare compatto, leggero e robusto, utilizzando collanti atossici resistenti all'acqua. Vengono infine rivestiti in laminato plastico antigraffio (finitura al quarzo).

I piani in linoleum sono realizzati in truciolare compatto rivestiti in linoleum nero opaco monostrato su tela di juta naturale (spessore 2 mm), la quale risulta una superficie liscia e antistatica, resistente alla decolorazione, all'usura, grassi ed agli acidi e alla brace delle sigarette. Inoltre mantiene una buona conservazione mediante il trattamento con cere autolucidanti.

GB

All top shelves have the side edges protected by impact-resistant ABS sidewalls. It's also to create holes (both on the top floor and on the metal structure) equipped with plastic caps.

Top shelf can be manufactured in **laminated light gray color** (depth 730 mm) or **laminated anthracite** (depth 760 mm) or **black linoleum** (depth 730 mm).

Laminates are made of compact, lightweight and sturdy chipboard, using non-toxic water-resistant glue. They are then covered with plastic laminate scratch-resistant (quartz finish).

Linoleum tops are made of compact chipboard covered with opaque black mono-layer linoleum on natural jute canvas (2 mm thick), which is a smooth, antistatic, resistant to discoloration, wear, oily and acids and cigarettes burn. It also keeps a good preservation by treatment with self-polishing waxes.

Dimensioni banco Counter dimension

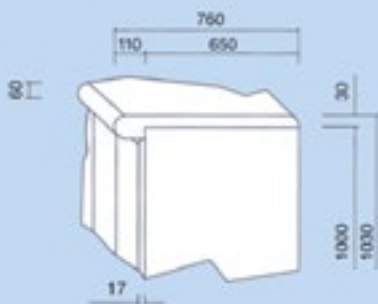

Piano laminato antracite
Laminated anthracite top shelf

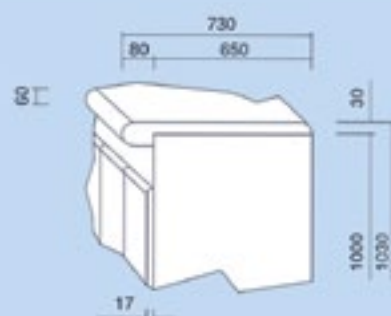

Piano laminato grigio chiaro o linoleum
Laminated light grey or linoleum top shelf

ANTARES

Lato rivolto al pubblico
External side

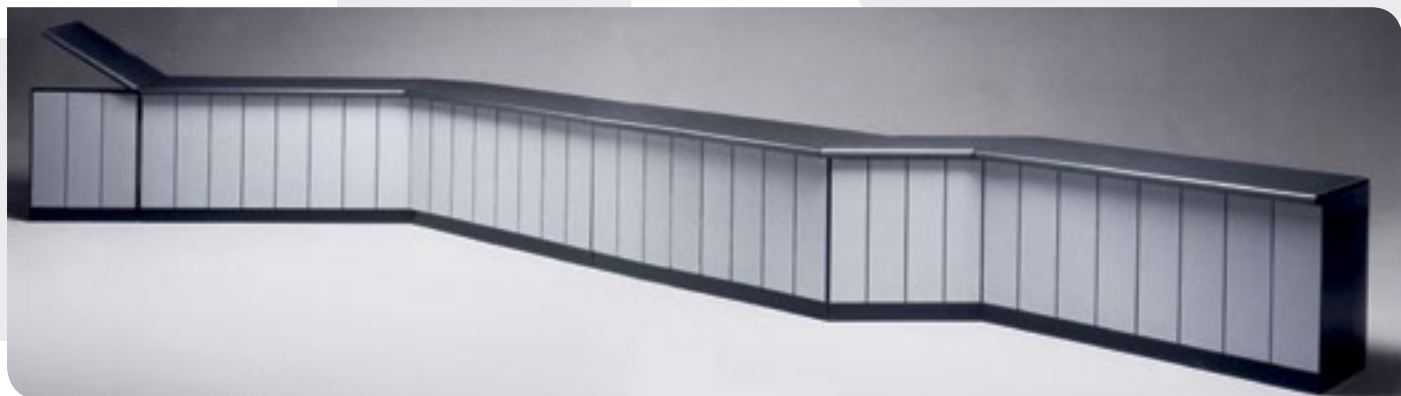

IT

Banconata con pannelli anteriori in laminato grigio chiaro ad elementi verticali, h 860 mm.

Disponibile con i seguenti interni: banco cassa, mod. 110, mod. 111, mod. 200, mod. 210, mod. 300.

GB

Counter with vertical front panels in light gray laminate, h 860 mm.

Available with the following inside: cash counter, mod. 110, mod. 111, mod. 200, mod. 210, mod. 300.



GIOVE

Lato rivolto al pubblico

External side

5

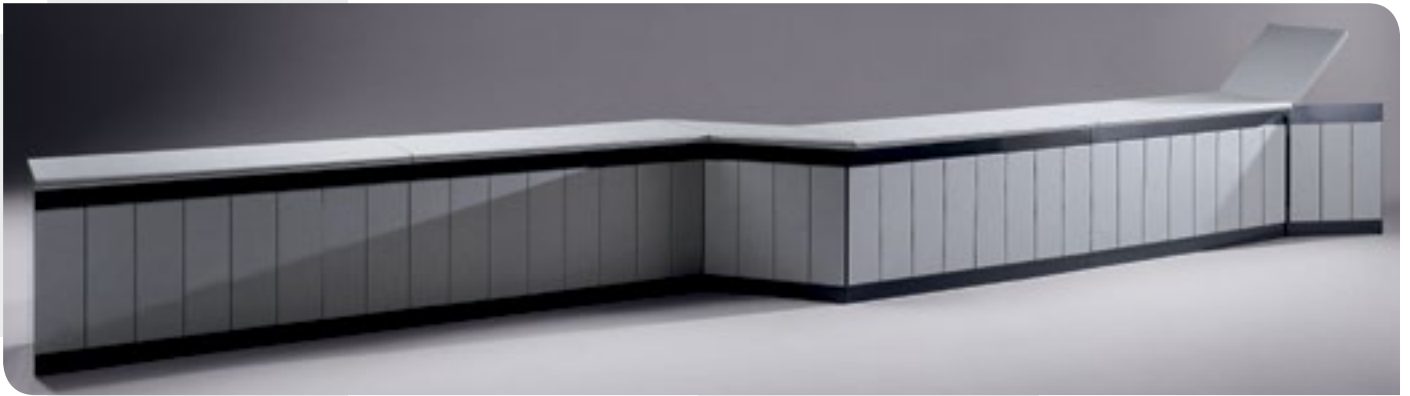

IT

Banconata con pannelli anteriori in laminato grigio chiaro ad elementi verticali, h 750 mm.
Disponibile con i seguenti interni: banco cassa, mod. 110, mod. 111, mod. 200, mod. 210, mod. 300.

GB

Counter with vertical front panels in light gray laminate, h 750 mm.
Available with the following inside: cash counter, mod. 110, mod. 111, mod. 200, mod. 210, mod. 300.



MIZAR

Lato rivolto al pubblico

External side



IT

Banconata con pannelli anteriori in laminato grigio chiaro ad elementi orizzontali, h 150 mm (complessivo h 750 mm). Disponibile con i seguenti interni: banco cassa, mod. 110, mod. 111, mod. 200, mod. 210, mod. 300.

GB

Counter with horizontal front panels in light gray laminate, h 150 mm (total h 750). Available with the following inside: cash counter, mod. 110, mod. 111, mod. 200, mod. 210, mod. 300.

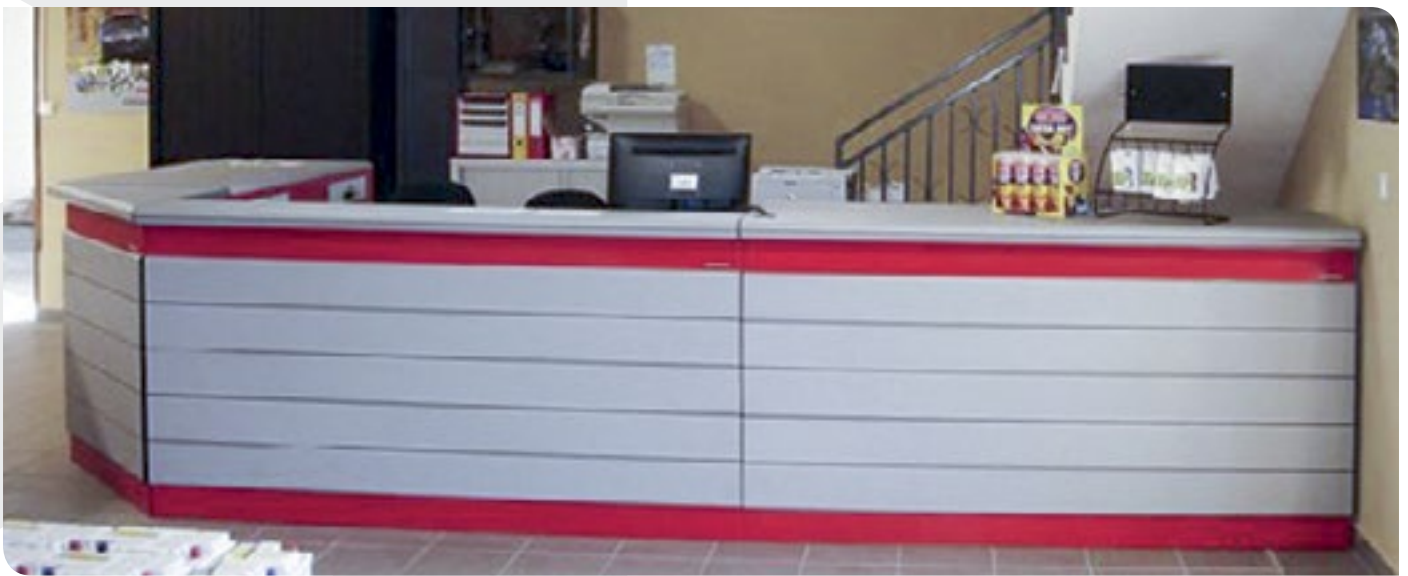

SIRIO

Lato rivolto al pubblico
External side

7



IT

Banconata con pannelli anteriori a rombo in lamiera verniciata.
Disponibile con i seguenti interni: banco cassa, mod. 110, mod. 111, mod. 200, mod. 210, mod. 300.

GB

*Counter with rhombus front panels in painted sheet.
Available with the following inside: cash counter, mod. 110, mod. 111, mod. 200, mod. 210, mod. 300.*



TITANO

Lato rivolto al pubblico
External side



IT

Banconata con elementi anteriori verticali in lamiera verniciata.
Disponibile con i seguenti interni: banco cassa, mod. 110, mod. 111, mod. 200, mod. 210, mod. 300.

GB

Counter with vertical front elements in painted sheet.
Available with the following inside: cash counter, mod. 110, mod. 111, mod. 200, mod. 210, mod. 300.



URANO

Lato rivolto al pubblico
External side

9



IT

Banconata con finitura anteriore a vetri scorrevoli su guide di alluminio (interno vetrina verniciato di bianco).
Disponibile con i seguenti interni: mod. 110, mod. 111, mod. 200, mod. 210.

GB

Counter with front glasses sliding on aluminum rails (window inside painted in white).
Available with the following inside: mod. 110, mod. 111, mod. 200, mod. 210.



Lato rivolto all'operatore *Internal side*

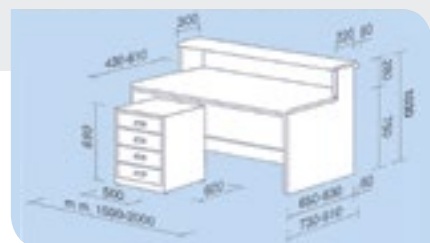
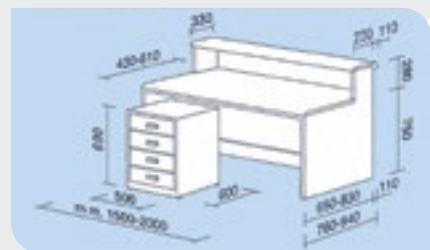

IT

BANCO SCRIVANIA CASSA

Dimensioni piano lavoro mm 1500/2000 x 650/830 x h 750.
Dimensioni piano al pubblico mm 1500/2000 x 300/330 x h 1030.
Cassettiera indipendente di dimensioni mm 500 (largh.) x mm 600 (prof.) mm 690 (altezza) con 4 ruote girevoli, provvista di 4 cassetti mm 400 x 470 x h 110, quello superiore con serratura.
Eventuale predisposizione foro per passaggio cavi.

GB

CASH COUNTER

Worktop dimensions mm 1500/2000 x 650/830 x h 750.
Front top dimensions mm 1500/2000 x 300/330 x h 1030.
Independent chest of drawers dimensions: mm 500 (width) x mm 600 (depth) mm 690 (height) with 4 revolving wheels and with 4 drawers mm 400 x 470 x h 110, the upper one with lock.
Possibility to make holes for cables.

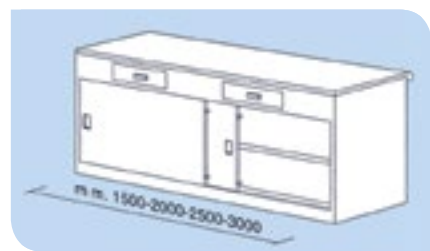

IT

BANCO MOD. 110

Dimensioni banco: mm 1500/2000/2500/3000 x 650 x h 1030.
Provvisto di sottopiano con 2 cassetti scorrevoli, dim. 400 x 470 x h 70. Serratura di serie su di un cassetto.
Dotato internamente di un ripiano fisso.
Chiuso da portine scorrevoli su apposite guide.

GB

COUNTER MOD. 110

Counter dimensions: mm 1500/2000/2500/3000 x 650 x h 1030.
Equipped with under-counter with 2 sliding drawers, dim. 400 x 470 x h 70. One drawer is supplied with standard lock.
Supplied with an internal fixed shelf.
Closed by sliding doors on dedicated rails.

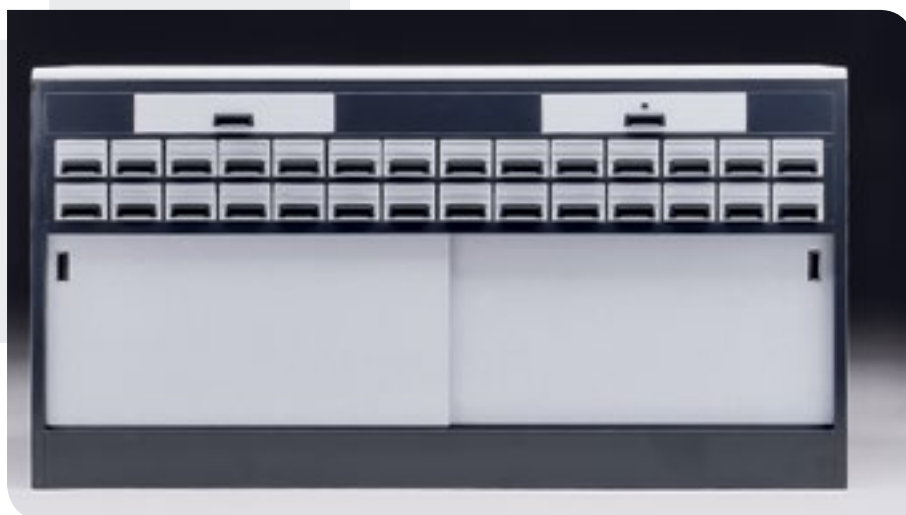

IT

BANCO MOD. 111

Dimensioni banco: mm 2000/2500/3000 x 650 x h 1030.
 Provvisto di sottopiano con 2 cassetti scorrevoli da mm 400 x 470 x h 70. Serratura di serie su di un cassetto.
 A seconda delle dimensioni, il banco è dotato rispettivamente di 28-36-44 cassettoni in lamiera verniciata da mm 290 x 120 x h 70, scorrevoli su guide in lamiera e provvisti di 3 separatori, ciascuno in lamiera zincata. Tali cassetti sono adatti per piccola minuteria. Fornito con un ripiano interno fisso. Chiuso da portine scorrevoli su apposite guide.

GB

COUNTER MOD. 111

Counter dimensions: mm 2000/2500/3000 x 650 x h 1030.
 Equipped with under-counter with 2 sliding drawers, dim. mm 400 x 470 x h 70. One drawer is supplied with standard lock.
 Depending on the size of the counter, it is equipped respectively with 28-36-44 painted metal drawers (dim. mm 290 x 120 x h 70), sliding on rails and each equipped with 3 galvanized partitions. These drawers are suitable for small parts. Supplied with an internal fixed shelf. Closed by sliding doors on dedicated guide.



IT

BANCO MOD. 200

Dimensioni banco: mm 2000/2500/3000 x 650 x h 1030.
 Provvisto di sottopiano con rispettivamente, a seconda delle misure del banco, 4-5-6 cassetti scorrevoli, da 400 x 470 x h 70. Serratura di serie su di un cassetto.
 Tali cassetti sono dotati rispettivamente di 18-26-36 divisori in lamiera verniciata che formano altrettante caselle. È adatto al contenimento di cataloghi, listini, depliant, ecc.

GB

COUNTER MOD. 200

Counter dimensions: mm 2000/2500/3000 x 650 x h 1030.
 Equipped with under-counter, which, depending on the size of the counter, is supplied with 4-5-6 sliding drawers (dim. 400 x 470 x h 70). One drawer is supplied with standard lock.
 These drawers are provided with respectively 18-26-36 painted metal partitions, forming as many boxes. It is suitable for containing lists, catalogs, brochures, etc.

Lato rivolto all'operatore

Internal side



IT

BANCO MOD. 210

Dimensioni banco: mm 2000/2500/3000 x 650 x h 1030.
A seconda delle dimensioni, il banco è provvisto rispettivamente di 54-66-78 cassetti di mm 500 x 210 x h 100 in lamiera verniciata con 3 separatori zincati cadauno. Tali cassetti sono scorrevoli su guide in lamiera. Questo modello di banco è indicato per contenere grossa minuteria, bulloneria, ecc.

GB

COUNTER MOD. 210

Counter dimensions: mm 2000/2500/3000 x 650 x h 1030.
Depending on the size of the counter, it is equipped with respectively 54-66-78 painted metal drawers (mm 500 x 210 x h 100), each one with 3 galvanized partitions. These drawers are sliding on metal rails. This model of counter is ideal for storing hardware, bolts, etc.



IT

BANCO MOD. 300

Dimensioni banco: mm 1500/2000/2500/3000 x 650 x h 1030.
A seconda delle dimensioni, il banco è provvisto rispettivamente di 21 / 28 / 35 / 42 cassetti mm 400 x 470 in lamiera verniciata.
Le due file inferiori dispongono di cassetti h 110, mentre le altre file dispongono di cassetti h 70. Possibilità di chiusura con serratura solo sulla fila di cassetti superiore (a richiesta). I cassetti scorrono su guide a cuscinetti robusti e silenziosi. Possibilità, su richiesta, di suddividere i cassetti in 8 / 15 / 24 caselle. Questo modello di banco è indicato per contenere piccola viteria, guarnizioni, minuteria e oggettistica varia.

GB











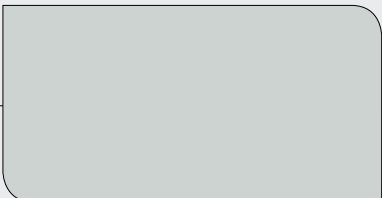
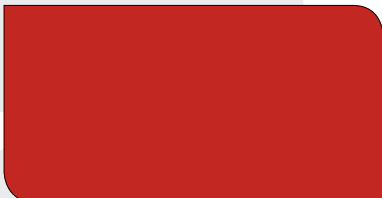
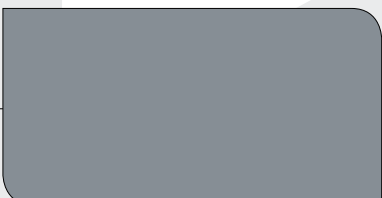
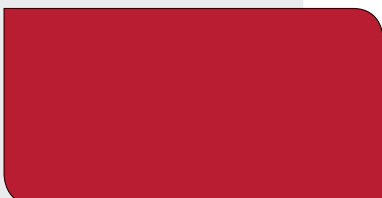
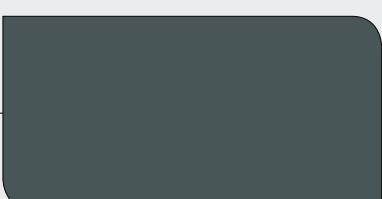

COUNTER MOD. 300

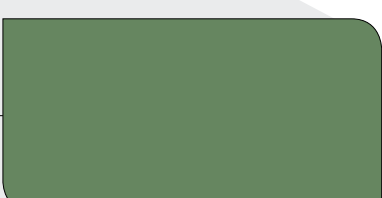
Counter dimensions: mm 1500/2000/2500/3000 x 650 x h 1030.
Depending on the size of the counter, it is equipped with respectively 21 / 28 / 35 / 42 painted metal drawers (mm 400 x 470).
Drawers of the two lower rows are high 110 mm, while the drawers of other lines are high 70 mm.
It is possible to have locks on demand only in the upper line of drawers. These drawers are sliding on strong rails. On demand drawers can be divided in 8 / 15 / 24 boxes.
This model of counter is ideal for storing small screws, gaskets, hardware and various objects.

Gamma colori disponibili

Colours available

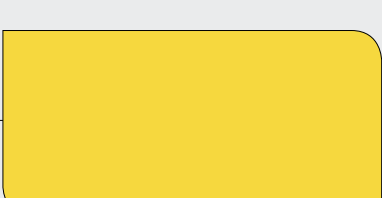
13

COD. 20 Bianco <i>White</i>			COD. 03 Nero <i>Black</i>
COD. 02 Grigio chiaro <i>Light grey</i>			COD. 23 Aragosta <i>Orange</i>
COD. 01 Grigio medio <i>Medium grey</i>			COD. 22 Rosso <i>Red</i>
COD. 31 Grigio scuro <i>Dark grey</i>			COD. 06 Beige <i>Beige</i>
COD. 25 Verde reseda <i>Light green</i>			COD. 05 Marrone <i>Brown</i>
COD. 08 Verde scuro <i>Dark green</i>			COD. 26 Bleu chiaro <i>Light blue</i>
COD. 24 Verde menta <i>Bright green</i>			COD. 04 Bleu scuro <i>Dark blue</i>
COD. 21 Giallo <i>Yellow</i>			COD. 35 Ocra <i>Ochre</i>

I colori riportati sono da ritenersi indicativi. Il bianco, il beige, il marrone, il verde scuro e il giallo sono colori fuori serie e pertanto disponibili su richiesta.

Please note that colours shown are to be considered indicative. White, beige, brown, dark green and yellow are not standard colours and therefore they are available on request.

Banchi modello Simplex

Simplex counter



Particolari della
struttura interna
Interior details

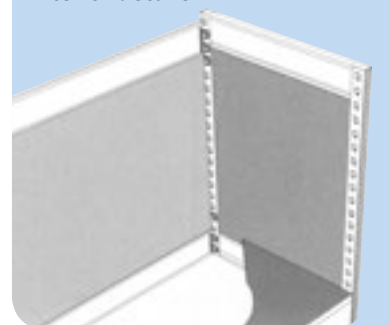

IT

Una linea di prodotto molto versatile e facile da trasportare e montare, ideata per coloro che hanno la necessità di inserire un banco vendita in spazi di minori dimensioni senza rinunciare alle esigenze di arredo e alla soddisfazione dei bisogni pratici dell'utilizzatore finale.

In particolare i banchi simplex sono il risultato della fusione della linea di produzione Mobilfer "scaffalature simplex" (stessa struttura metallica e stessi accessori) con le caratteristiche e le configurazioni studiate per la linea Mobilfer "banchi vendita".

Il risultato è una linea di banchi estremamente flessibile, in grado di soddisfare al meglio le esigenze di vendita nei più svariati settori merceologici, dai magazzini di ricambi, alle ferramenta, ai negozi commerciali, ai luoghi che necessitano di banchi informazioni, etc.

GB

This product line is very versatile and easy to carry and assemble. It is designed for those who have the need to fit a sales counter in smaller spaces without sacrificing the wishes of a design furniture and the satisfaction of practical needs of the end user.

In particular, simplex counters are the result of the merger of Mobilfer product line "simplex" (same metal structure and same accessories) with the features and configurations designed for Mobilfer product line "sales counters".

The result is a line of benches extremely flexible, able to satisfy the needs of sales in various sectors, from spare parts stores, to hardware store, shopping malls, places that need information desks, etc.



COD. 0243700
Modello base
Base model



COD. 0247700
Cassettiera con 8 cassetti
Chest with 8 drawers



COD. 0248000
Modello cassa
Cash model



COD. 0243100
Modello 1/C
1/C model



SCAFFALATURE METALLICHE

Via Bergoncino, 70
36025 Noventa Vicentina (VI)
Tel. 0444.788800
Fax 0444.788850
Web site: www.mobilfer.it
E-mail: info@mobilfer.it

Mobilfer si riserva il diritto di modificare le caratteristiche del prodotto senza alcun preavviso.